

Engine Protection	Document: Manual	<b>G4</b> <b>Fuel Stop Solenoid</b>	<b>HUGLI</b> HUEGLI TECH LTD SWITZERLAND Tel.: +41-62-916 50 30 Fax. +41-62-916 50 35 www.huegli-tech.com
	Version: 1		
Status: actual			
Author: eb    Date: 05-05-11			
Approved: lh    Date: 05-05-11			
File: PC			

# Reliable *Overspeed* Protection with the G4 Diesel Fuel Stop Solenoid

Patented 2/4 Way valve

Patent No. 97 830 22 06

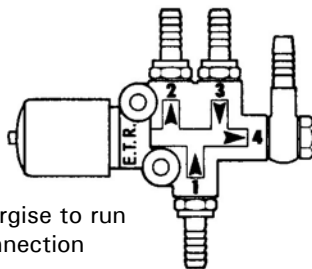
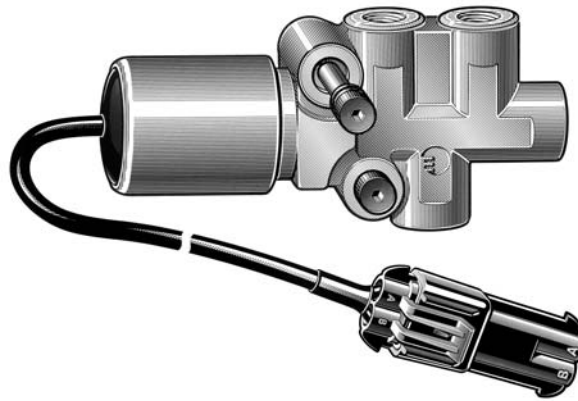

Energise to run  
Connection

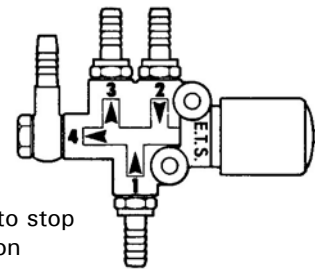

Energise to stop  
Connection

1. This 2/4 Way Solenoid Valve will **very reliably** stop a diesel engine in any situation.
2. Because, contrary to normal stop solenoids, which act on the pump stop lever and become ineffective whenever the fuel rack sticks, this valve acts directly on the fuel supply to the pump.
3. In stop position the suction side of a fuel supply pump and its output side are reversed, which then creates an instant vacuum in the fuel injection pump galley, the engine speed immediately drops to zero.
4. The same valve can be used in "energized to run" or "energized to stop" mode simply by reversing the connecting hoses.
5. The installation of the G4 valve is quite simple. Attached description illustrates the connecting method for both modes, which are also marked on the valve itself.

Engine Protection	Document: Manual	<b>G4 Fuel Stop Solenoid</b>	<b>HUGLI</b> HUEGLI TECH LTD SWITZERLAND Tel.: +41-62-916 50 30 Fax. +41-62-916 50 35 www.huegli-tech.com
	Version: 1		
	Status: actual		
	Author: eb	Date: 05-05-11	
	Approved: lh	Date: 05-05-11	
	File: PC		

## 1. Energised to run connection - E.T.R. valve side

### 1.1 Working Position

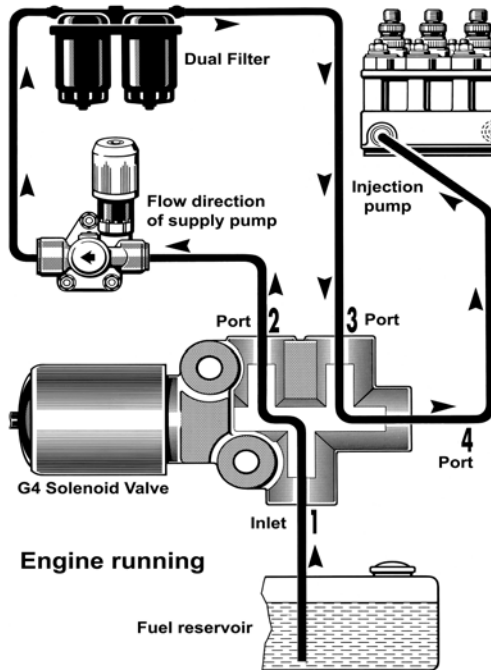

On the E.T.R. side of the valve the flow direction at the connecting ports is marked with arrows.

When Voltage is applied, the spool moves in the operating position.

The fuel is aspirated through Inlet port „1“, through to outlet port „2“, and to the fuel supply pump.

The supply pump forces the fuel through the filters into G4 port „3“ and from outlet „4“ to the fuel injection pump.

The engine can thus only run when the valve is **energised**.

### 1.2 Stop Position

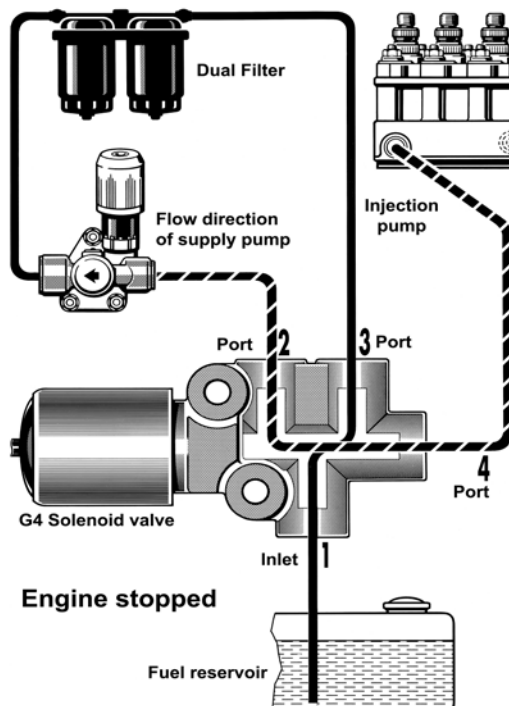

When the supply voltage is shut off, the valve spool instantly moves to Stop position.

The suction of the supply pump is thus re-directed to the fuel injection pump where it creates a vacuum in the galley.

The injection to the nozzles instantly stop, the engine speed drops to zero.

Note: After the engine is at stand still, it can be immediately restarted because the fuel injection pump galley is not emptied during the stopping process.

Engine Protection	Document: Manual	<b>G4</b> <b>Fuel Stop Solenoid</b>	<b>HUGLI</b> HUEGLI TECH LTD SWITZERLAND Tel.: +41-62-916 50 30 Fax. +41-62-916 50 35 www.huegli-tech.com
	Version: 1 Status: actual Author: eb Date: 05-05-11 Approved: lh Date: 05-05-11 File: PC		

## 2. Energised to Stop connections - E.T.S. valve side

### 2.1. Operating position

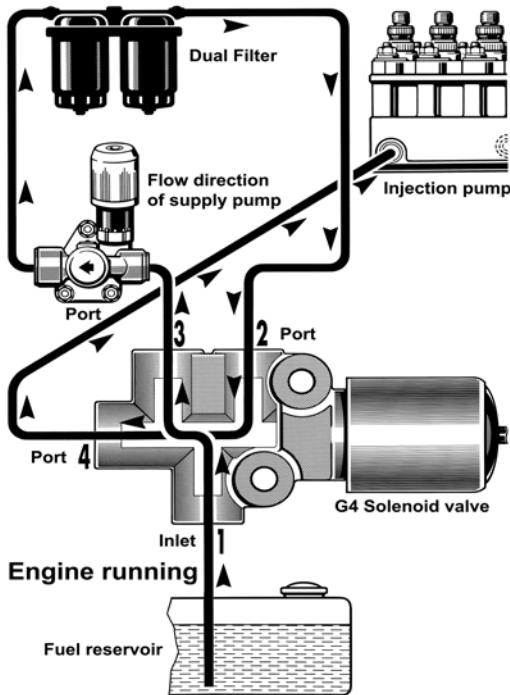

In this mode the supply pump aspirates the fuel from the reservoir into port „1“, through port „3“, through the filters and via valve port „2“ and outlet „4“ into the fuel injection pump.

The correct flow direction is again marked by arrows on the E.T.S. side.

The engine can thus only run when the valve is **not** energized.

### 2.1. Stop position

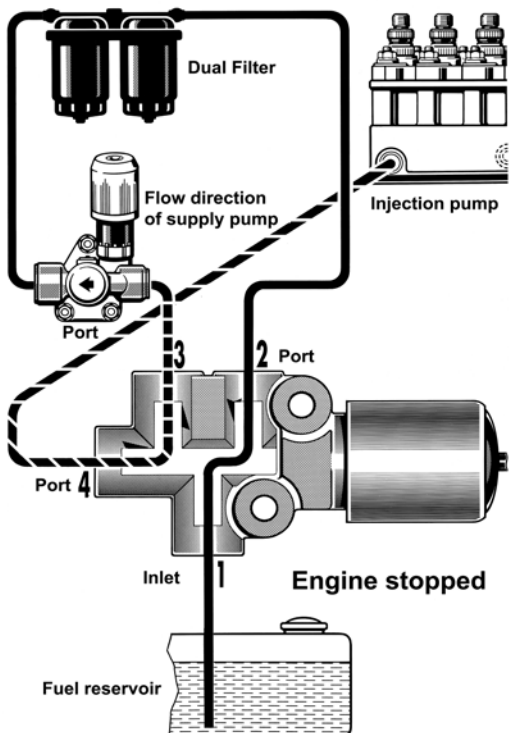

In this mode, the engine is stopped by energizing the Solenoid.

Exactly as in the E.T.R. mode the flow direction is reversed when the valve is energized, which will cause the engine to instantly stop.

Restarting is immediately possible.

Engine Protection	Document: Manual	<b>G4</b> Fuel Stop Solenoid	<b>HUGLI</b> HUEGLI TECH LTD SWITZERLAND Tel.: +41-62-916 50 30 Fax. +41-62-916 50 35 www.huegli-tech.com
	Version: 1		
	Status: actual		
	Author: eb	Date: 05-05-11	
	Approved: lh	Date: 05-05-11	
	File: PC		

### 3. Dimension of the G4 valve

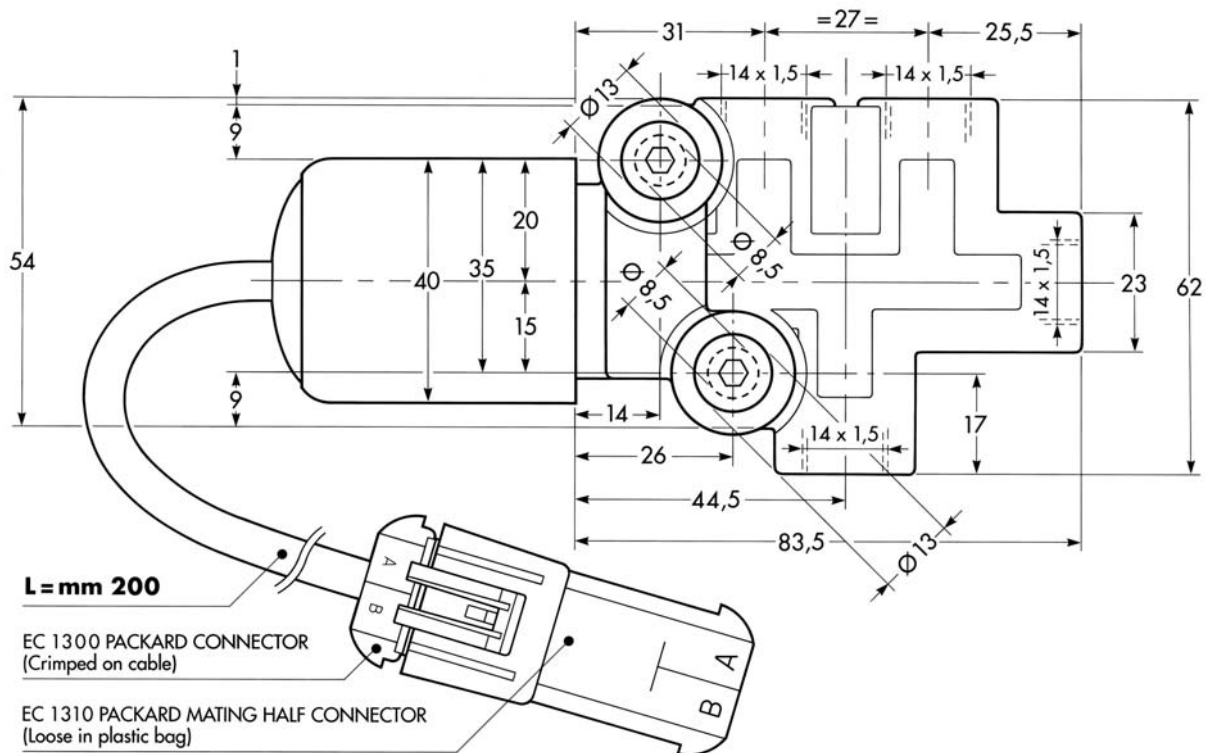
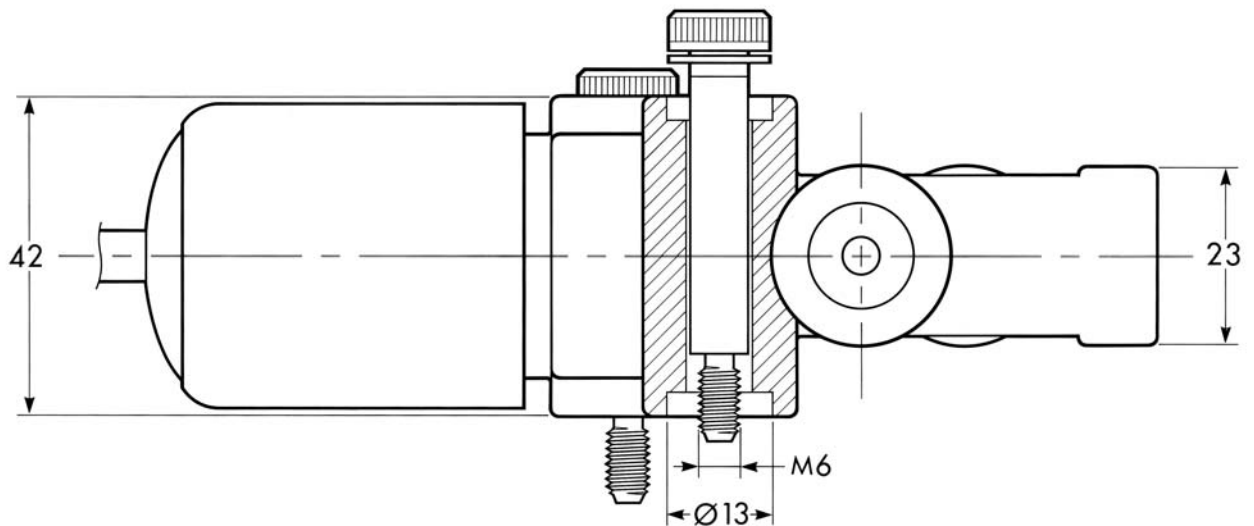

<b>Engine</b>  <b>Protection</b>	<b>Document:</b> Manual <b>Version:</b> 1 <b>Status:</b> actual <b>Author:</b> eb <b>Date:</b> 05-05-11 <b>Approved:</b> lh <b>Date:</b> 05-05-11 <b>File:</b> PC	<b>G4</b> <b>Fuel Stop Solenoid</b>	 <b>HUEGLI TECH LTD</b> <b>SWITZERLAND</b> Tel.: +41-62-916 50 30 Fax. +41-62-916 50 35 www.huegli-tech.com
--	--	--	---

## 4. Technical Specification

Working Principle	:	2 position 4 way solenoid valves with sleeve
Supply voltages		
G4 – 12 Volt	:	10.0 – 14.4 VDC (- 40°C to +100°C)
G4 – 24 Volt	:	20.0 – 28.8 VDC (- 40°C to +100°C)
Current consumption		
G4 – 12 Volt	:	0.70 – 1.3 Amp.
G4 – 24 Volt	:	0.41 – 0.72 Amp.
Max. Pressure	:	4.5 bar at injection pump
Flow rate	:	4 Liter / Min.
Duty Cycle	:	100% duration
Temperature range	:	- 40°C to +130°C
Vibration shock	:	up to 20 G, @ 50 – 500 Hz
Electrical connection	:	Cable 200 mm long with Packard connector EC 1300 Mating connector EC 1310 included
Insulation class	:	H – tested at 1600 VDC against ground
Certification	:	CE, according EN 50082-1, EN 50082-2 and EN 50081-1, EN 50081-2

<b>Engine</b>  <b>Protection</b>	<b>Document:</b> Manual <b>Version:</b> 1 <b>Status:</b> actual <b>Author:</b> eb <b>Date:</b> 05-05-11 <b>Approved:</b> lh <b>Date:</b> 05-05-11 <b>File:</b> PC	<b>G4</b> <b>Fuel Stop Solenoid</b>	 <b>HUEGLI TECH LTD</b> <b>SWITZERLAND</b> Tel.: +41-62-916 50 30 Fax: +41-62-916 50 35 www.huegli-tech.com

## 5. Installation Instruction

- 5.1 In order to avoid distortion of the valve body, the valve must be fixed on to a flat, rigid, unbendable surface, ideally close to the fuel injection pump. The fixation screws must be tightened with 12 – 1 NM. The distance between valve outlet and fuel Injection pump should be within 200mm.
- 5.2 As fuel lines, flexible hoses suitable for engine environment are recommended, in case of rigid metal pipes make sure that the flat surfaces of the swivel fittings are flush and well aligned with the valve surfaces, so that the valve body will not be distorted when tightening the fittings. Valve body distortion can cause valve malfunction. In case the fuel from the reservoir is contaminated, an additional filter should be fitted between reservoir and G4 valve inlet.
- 5.3 The flat gaskets in conjunction with swivel fittings are either of steel or aluminium with rubber inserts (P/ No.1 205 621) or of annealed copper, size  $\varnothing$  14.3 x 1.5.

The correct torque values which must be applied are:

With steel or aluminium gaskets	30 – 35 NM
With annealed copper gaskets	35 – 40 NM

After completion check for proper functioning by switching the power several times on and off.

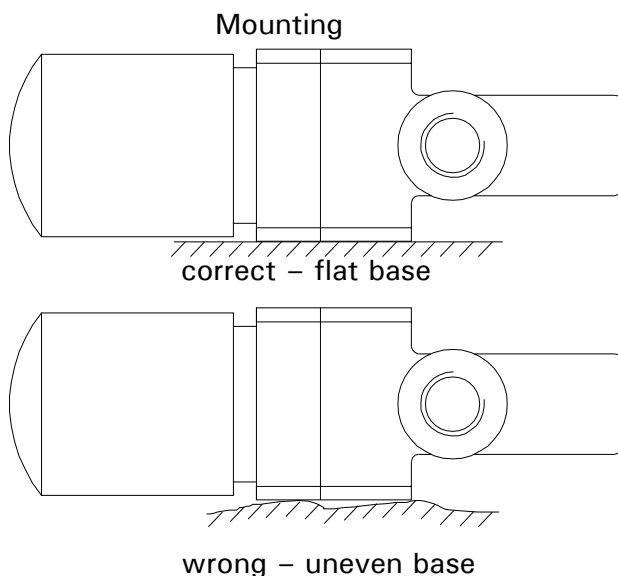

Aligned all swivel fittings before tightening, to avoid distortion forces on to the valve body

