

# ESD-5200 Series Speed Control Unit

## Manual

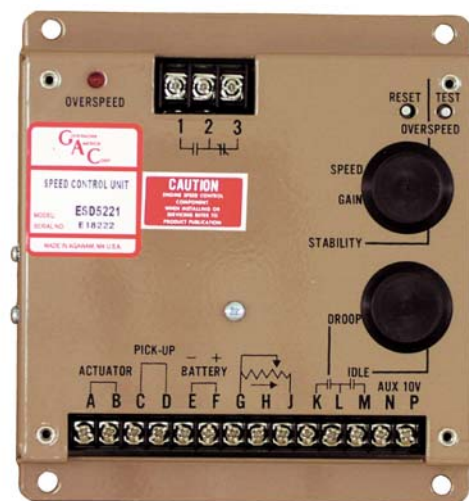

Doc.-No. : ESD-5200\_TI-EN\_11.2011

Version : 1.1

Date of Issue : 03.11.2011

HUEGLI TECH Switzerland

This document, and the information contained herein is the intellectual property of HUEGLI TECH. It is to be used only in conjunction with the specific system or the specific equipment for which it was meant, and may not be used for any other purpose. The copyright has been applied to every page. We reserve all rights for this document, also in the event of application for patents or registry of patterns or designs. None of the information contained herein may be disclosed to third parties, nor may it be reproduced, copied or transmitted in any way, shape or form, or by any means, electronic, mechanical, or otherwise, without the prior written permission of HUEGLI TECH.

Unless otherwise stated, masculine nouns and pronouns do not refer exclusively to men.

All trademarks used in this document are properties of their respective owners.

### Table of Contents

<b>1</b>	<b>Installation</b> .....	<b>4</b>
<b>2</b>	<b>Wiring</b> .....	<b>4</b>
<b>3</b>	<b>Adjustments</b> .....	<b>5</b>
3.1	Before Starting Engine .....	5
3.2	Start Engine .....	5
3.3	Governor Speed Setting .....	5
3.4	Governor Performance .....	5
3.5	Idle Speed Setting .....	6
3.6	Speed Droop Operation .....	6
3.7	Accessory Input .....	6
3.8	Accessory Supply .....	7
3.9	Internal Speed Switch .....	7
3.10	Wide Range Remote Variable Speed Operation .....	7
<b>4</b>	<b>Table 1</b> .....	<b>8</b>
<b>5</b>	<b>Diagram 1</b> .....	<b>8</b>
<b>6</b>	<b>System Troubleshooting</b> .....	<b>8</b>
6.1	Insufficient Magnetic Speed Signal .....	8
6.2	Electromagnetic Compatibility (EMC) .....	9
6.3	Instability .....	9
6.4	System Inoperative .....	10
6.5	Unsatisfactory Performance .....	11
<b>7</b>	<b>Diagram 2. - System Wiring/Outline</b> .....	<b>12</b>
<b>8</b>	<b>Specifications</b> .....	<b>13</b>
8.1	Performance .....	13
8.2	Environmental .....	13
8.3	Input Power .....	13
8.4	Reliability .....	13
8.5	Physical .....	13

## 1 Installation

The speed control unit is rugged enough to be placed in a control cabinet or engine mounted enclosure with other dedicated control equipment. If water, mist, or condensation may come in contact with the controller, it should be mounted vertically. This will allow the fluid to drain away from the speed control unit. Extreme heat should be avoided.



### WARNING

An overspeed shutdown device, independent of the governor system, should be provided to prevent loss of engine control, which may cause personal injury or equipment damage. Do not rely exclusively on the governor system electric actuator to prevent overspeed. A secondary shutoff device, such as a fuel solenoid, must be used.

## 2 Wiring

Basic electrical connections are illustrated in Diagram 2. Actuator and battery connections to Terminals A, B, E, and F should be #16 AWG (1.3 mm sq.) or larger. Long cables require an increased wire size to minimize voltage drops.

The battery positive (+) input, Terminal F, should be fused for 15 amps as illustrated. The ESD-5200 SERIES is suitable for 12V DC and 24V DC operations.

Magnetic speed sensor wires connected to Terminals C and D **MUST BE TWISTED AND/OR SHIELDED** for their entire length. The speed sensor cable shield should ideally be connected as shown in Diagram 2. The shield should be insulated to insure no other part of it comes in contact with engine ground, otherwise stray speed signals may be introduced into the speed control unit. With the engine stopped, adjust the gap between the magnetic speed sensor and the ring gear teeth. The gap should not be any smaller than 0.020 in. (0.45 mm). Usually, backing out the speed sensor 3/4 turn after touching the ring gear teeth will achieve a satisfactory air gap. The magnetic speed sensor voltage should be at least 1V AC RMS during cranking.

### 3 Adjustments

#### 3.1 Before Starting Engine

Check to insure the **GAIN** and **STABILITY** adjustments, and if applied, the external **SPEED TRIM CONTROL** are set to mid position.

#### 3.2 Start Engine

The speed control unit governed speed setting is factory set at approximately engine idle speed (1000 Hz., speed sensor signal).

Crank the engine with DC power applied to the governor system. The actuator will energize to the maximum fuel position until the engine starts. The governor system should control the engine at a **low idle** speed. If the engine is unstable after starting, turn the **GAIN** and **STABILITY** adjustments counterclockwise until the engine is stable.

#### 3.3 Governor Speed Setting

The governed speed set point is increased by clockwise rotation of the **SPEED** adjustment pot. Remote speed adjustment can be obtained with an optional 5K Speed Trim Control. (See Diagram 2)

#### 3.4 Governor Performance

Once the engine is at operating speed and at no load, the following governor performance adjustment can be made.

- A. Rotate the **GAIN** adjustment clockwise until instability develops. Gradually move the adjustment counterclockwise until stability returns. Move the adjustment one division further counterclockwise to insure stable performance (270° pot).
- B. Rotate the **STABILITY** adjustment clockwise until instability develops. Gradually move the adjustment counterclockwise until stability returns. Move the adjustment one division further to insure stable performance (270° pot).
- C. Gain and stability adjustments may require minor changes after engine load is applied. Normally, adjustments made at no load achieve satisfactory performance. A strip chart recorder can be used to further optimize the adjustments.

If instability cannot be corrected or further performance improvements are required, refer below to the **SYSTEM TROUBLESHOOTING** section. In this section, information can be found regarding troubleshooting procedures as well as instructions on adjusting the DIP switch positions of the ESD-5231.

### 3.5 Idle Speed Setting

After the governor speed setting had been adjusted, place the optional external selector switch in the IDLE position. The idle speed set point is increased by clockwise of the IDLE adjustment control. When the engine is at idle speed, the speed control unit applies droop to the governor System to insure stable operation.

### 3.6 Speed Droop Operation

Droop is typically used for the paralleling of engine driven generators.

Place the optional external selector switch in the DROOP position. DROOP is increased by clockwise rotation of the DROOP adjustment control. When in droop operation, the engine speed will decrease as engine load increases. The percentage of droop is based on the actuator current change from engine no load to full load. A wide range droop is available with the internal control. Droop level requirements above 10% are unusual.

If droop levels experienced are higher or lower than these required, contact Huegli Tech for assistance.

After the droop level has been adjusted, the rated engine speed setting may need to be reset. Check the engines speed and adjust that speed setting accordingly.

### 3.7 Accessory Input

The **AUX**iliary Terminal N accepts input signals from load sharing units, auto synchronizers, and other governor system accessories, GAC accessories are directly connected to this terminal. It is recommended that this connection from accessories be shielded as it is a sensitive input terminal.

If the auto synchronizer is used alone, not in conjunction with a load-sharing module, a 3 M ohm resistor should be connected between Terminals N and P. This is required to match the voltage levels between the speed control unit and the synchronizer.

When an accessory is connected to Terminal N, the speed will decrease and the speed adjustment must be reset.

When operating in the upper end of the control unit frequency range, a jumper wire or frequency trim control may be required between Terminals G and J. This increases the frequency range of the speed control to over 7000 Hz.

### 3.8 Accessory Supply

The +10V DC regulated supply, Terminal P, can be utilized to provide power to GAC governor system accessories. Up to 20 ma of current can be drawn from this supply. Ground reference is Terminal G. **Caution: A short circuit on this terminal can damage the speed control unit.**

### 3.9 Internal Speed Switch

When the engine is running at the desired speed, push and hold the TEST button. Rotate the OVERSPEED adjustment counterclockwise until the LED lights and the relay reenergizes. Current to the actuator will be removed and the engine will shut off.

Release the TEST button. After the engine stops, press the RESET button or remove the battery power. Restart the engine and it will return to the original speed setting.

The overspeed function is now set to approximately 10% above the requested speed. If a different value for overspeed is required, standard procedure for adjustment should be used.

Always use the relay contacts provided to shut down the system by a means other than the governor or actuator. It is recommended that the overspeed protection system be tested and verified during scheduled service of equipment.

### 3.10 Wide Range Remote Variable Speed Operation

Simple and effective remote variable speed can be obtained with the ESD-5200 Series speed control unit.

A single remote speed adjustment potentiometer can be used to adjust the engine speed continuously over a specific speed range. Select the desired speed range and corresponding potentiometer value. (Refer to TABLE 1.) If the exact range cannot be found, select the next higher range potentiometer. An additional fixed resistor may be placed across the potentiometer to obtain the exact desired range. Connect the speed range potentiometer as shown in Diagram 1.

To maintain engine stability at the minimum speed setting, a small amount of droop can be added using the DROOP adjustment. At the maximum speed setting the governor performance will be near isochronous, regardless of the droop adjustment setting.

Contact HUEGLI TECH for assistance if difficulty is experienced in obtaining the desired variable speed governing performance.

### 4 Table 1

#### VARIABLE SPEED RANGE POTENTIOMETER VALUE

Speed Range	Potentiometer Value
900 Hz.	1K
2,400 Hz.	5K
3,000 Hz.	10K
3,500 Hz.	25K
3,700 Hz.	50K

### 5 Diagram 1

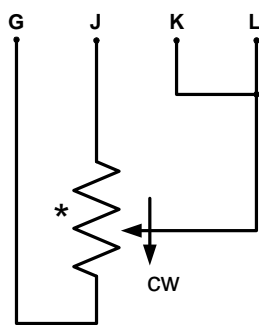

\*Select proper potentiometer value from Table 1

## 6 System Troubleshooting

### 6.1 Insufficient Magnetic Speed Signal

A strong magnetic speed sensor signal will eliminate the possibility of missed or extra pulses. While the speed control unit will govern well with 0.5V AC RMS speed sensor signal, a speed sensor signal of 3V AC RMS or greater at governed speed is recommended. Measure the signal at Terminals C and D.

The amplitude of the speed sensor signal can be raised by reducing the gap between the speed sensor tip and the engine ring gear. The gap should not be any smaller than 0.020 in (0.45 mm). When the engine is stopped, back the speed sensor out by 3/4 turn after touching the ring gear tooth to achieve a satisfactory air gap.



### 6.2 Electromagnetic Compatibility (EMC)

EMI SUSCEPTIBILITY - The governor system can be adversely affected by large interfering signals that are conducted through the cabling or through direct radiation into the control circuits.

All GAC speed control sensors contain filters and shielding designed to protect the unit's sensitive circuits from moderate external interfering sources.

Although it is difficult to predict levels of interference, applications that include magnetos, solid state ignition systems, radio transmitters, voltage regulators or battery chargers should be considered suspect as possible interfering sources.

If it is suspected that external fields, either those that are radiated or conducted, are or will affect the governor systems operation, it is recommended to use shielded cable for all external connections. Be sure that only one end of the shields, including the speed sensor shield, is connected to a single point on the case of the speed control unit. Mount the speed control to a grounded metal back plate or place it in a sealed metal box.

Radiation is when the interfering signal is radiated directly through space to the governing system. To isolate the governor system electronics from this type of interference source, a metal shield or a solid metal container is usually effective.

Conduction is when the interfering signal is conducted through the interconnecting wiring to the governor system electronics. Shielded cables and installing filters are common remedies.

In severe high-energy interference locations such as when the governor system is directly in the field of a powerful transmitting source, the shielding may require to be a special EMI class shielding. For these conditions, contact Huegli Tech for specific recommendations.

### 6.3 Instability

Instability in a closed loop speed control system can be categorized into two general types. **PERIODIC** appears to be sinusoidal and at a regular rate. **NON-PERIODIC** is a random wandering or an occasional deviation from a steady state band for no apparent reason.

The **PERIODIC** type can be further classified as fast or slow instability. Fast instability is a 3 Hz. or faster irregularity of the speed and is usually a jitter. Slow periodic instability is below 3 Hz., can be very slow, and is sometimes violent.

If fast instability occurs, this is typically the governor responding to engine firings. Raising the engine speed increases the frequency of instability and vice versa. In this case, setting LEAD switch SW1 in the "OFF" position will reduce this tendency. Readjust the GAIN and STABILITY for optimum control. In extreme cases, this may not take all the jitter out of the system. In this case, turn DTC switch SW2 to "OFF", to further stabilize the system. Switch locations are shown in Diagram 2.

Interference from powerful electrical signals can also be the cause. Turn off the battery chargers or other electrical equipment to see if the system instability disappears.

Slow instability can have many causes. First, DIP switches 1 and 2 should be turned "ON" in the following order: FIRST - SW1, SECOND - SW2, and THIRD SW1 & SW2. Adjustment of the **GAIN** and **STABILITY** usually cures most situations by matching the speed control unit dynamics. If this is unsuccessful, the dead time compensation can be modified. Add a capacitor between posts E2 to E3 (negative on E2). Post locations are illustrated in Diagram 2. Start with 10 mfd and increase until instability is eliminated. The control system can also be optimized for best performance by following this procedure.

If slow instability is unaffected by this procedure, evaluate the fuel system and engine performance. Check the fuel system linkage for binding, high friction, or poor linkage. Be sure to check linkage during engine operation. Also look at the engine fuel system. Irregularities with carburetion or fuel injection systems can change engine power with a constant throttle setting. This can result in speed deviations beyond the control of the governor system. Adding a small amount of droop can help stabilize the system for troubleshooting.

**NON-PERIODIC** instability should respond to the **GAIN** control. If increasing the gain reduces the instability, then the problem is probably with the engine. Higher gain allows the governor to respond faster and correct for disturbance. Look for engine mis-firings, an erratic fuel system, or load changes on the engine generator set voltage regulator. If the throttle is slightly erratic, but performance is fast, move switch C1 to the "OFF" position. This will tend to steady the system.

If unsuccessful in solving instability, contact Huegli Tech for assistance.

## 6.4 System Inoperative

If the engine governing system does not function, the fault may be determined by performing the voltage tests described in Steps 1 through 4. Positive (+) and negative (-) refer to meter polarity. Should normal values be indicated during troubleshooting steps, and then the fault may be with the actuator or the wiring to the actuator. Tests are performed with battery power on and the engine off, except where noted. See actuator publication for testing procedure on the actuator.

Step	Wires	Normal Reading	Probable Cause of Abnormal Reading
1	F(+) & E(-)	Battery Supply Voltage (12 or 24V DC)	<ol style="list-style-type: none"> <li>DC battery power not connected. Check for blown fuse</li> <li>Low battery voltage.</li> <li>Wiring error.</li> </ol>
2	C & D	1.0V AC RMS min. while cranking	<ol style="list-style-type: none"> <li>Gap between speed sensor and gear teeth too great. Check gap.</li> <li>Improper or defective wiring to the speed sensor. Resistance between D and C should be 30 to 1200 ohms.</li> <li>Defective speed sensor.</li> </ol>
3	P(+) & G(-)	10V DC, Internal Supply	<ol style="list-style-type: none"> <li>Short on Terminal P. (This will cause a defective unit.)</li> <li>Defective speed control unit.</li> </ol>
4	F(+) & A(-)	1.0 - 2.0V DC while cranking	<ol style="list-style-type: none"> <li>SPEED adjustment set too low.</li> <li>Short/open in actuator wiring.</li> <li>Defective speed control.</li> <li>Defective actuator. See Actuator Troubleshooting.</li> </ol>

## 6.5 Unsatisfactory Performance

If the governing system functions poorly, perform the following tests.

Symptom	Test	Probable Fault
Engine overspeeds	<ol style="list-style-type: none"> <li>Do Not Crank. Apply DC power to the governor system.</li> <li>Manually hold the engine at the desired running speed. Measure the DC voltage between Terminals A(-) &amp; F(+) on the speed control unit.</li> </ol>	<ol style="list-style-type: none"> <li>Actuator goes to full fuel. Then disconnect speed sensor at Terminal C &amp; D. If actuator still at full fuel-speed control unit defective. If actuator at minimum fuel position, erroneous speed signal. Check speed sensor cable.</li> <li>If the voltage reading is 1.0 to 2.0V DC, <ol style="list-style-type: none"> <li>SPEED adjustment set above desired speed.</li> <li>Defective speed control unit.</li> </ol> </li> <li>If the voltage reading is above 2.0V DC, actuator or linkage binding.</li> <li>Set point of overspeed shutdown device set too low</li> <li>If the voltage reading is below 1.0V DC, defective speed control unit.</li> </ol>
Overspeed shuts down engine after running speed is reached.		<ol style="list-style-type: none"> <li>Speed adjustment set too high.</li> <li>OVERSPEED set to close to running speed.</li> <li>Actuator or linkage binding.</li> <li>Speed control unit defective.</li> </ol>
Overspeed shuts down engine before running speed is reached.	Check impedance between Terminals C & D. Should be 30 to 1200 ohms.	<ol style="list-style-type: none"> <li>OVERSPEED set too low. Adjust 5-6 turns CW.</li> <li>Erroneous speed sensor signal. Check wiring.</li> </ol>
Actuator does not energize fully	<ol style="list-style-type: none"> <li>Measure the voltage at the battery while cranking.</li> <li>Momentarily connect Terminals A and F. The actuator should move to the full fuel position.</li> </ol>	<ol style="list-style-type: none"> <li>If the voltage is less than 7V for a 12V system, or 14V for a 24V system, check or replace the battery</li> <li>Actuator or battery wiring in error.</li> <li>Actuator or linkage binding.</li> <li>Defective actuator.</li> <li>Fuse opens. Check for short in actuator or harness.</li> </ol>
Engine remains below desired governed speed	1. Measure the actuator output, Terminals A & B, while running under governor control.	<ol style="list-style-type: none"> <li>If voltage measurement is with 2V DC or more of the battery supply voltage level, then fuel control restricted from reaching full fuel position. Possibly due to mechanical governor, carburetor spring, or linkage interference.</li> <li>Speed setting too low.</li> </ol>

**7 Diagram 2. - System Wiring/Outline**

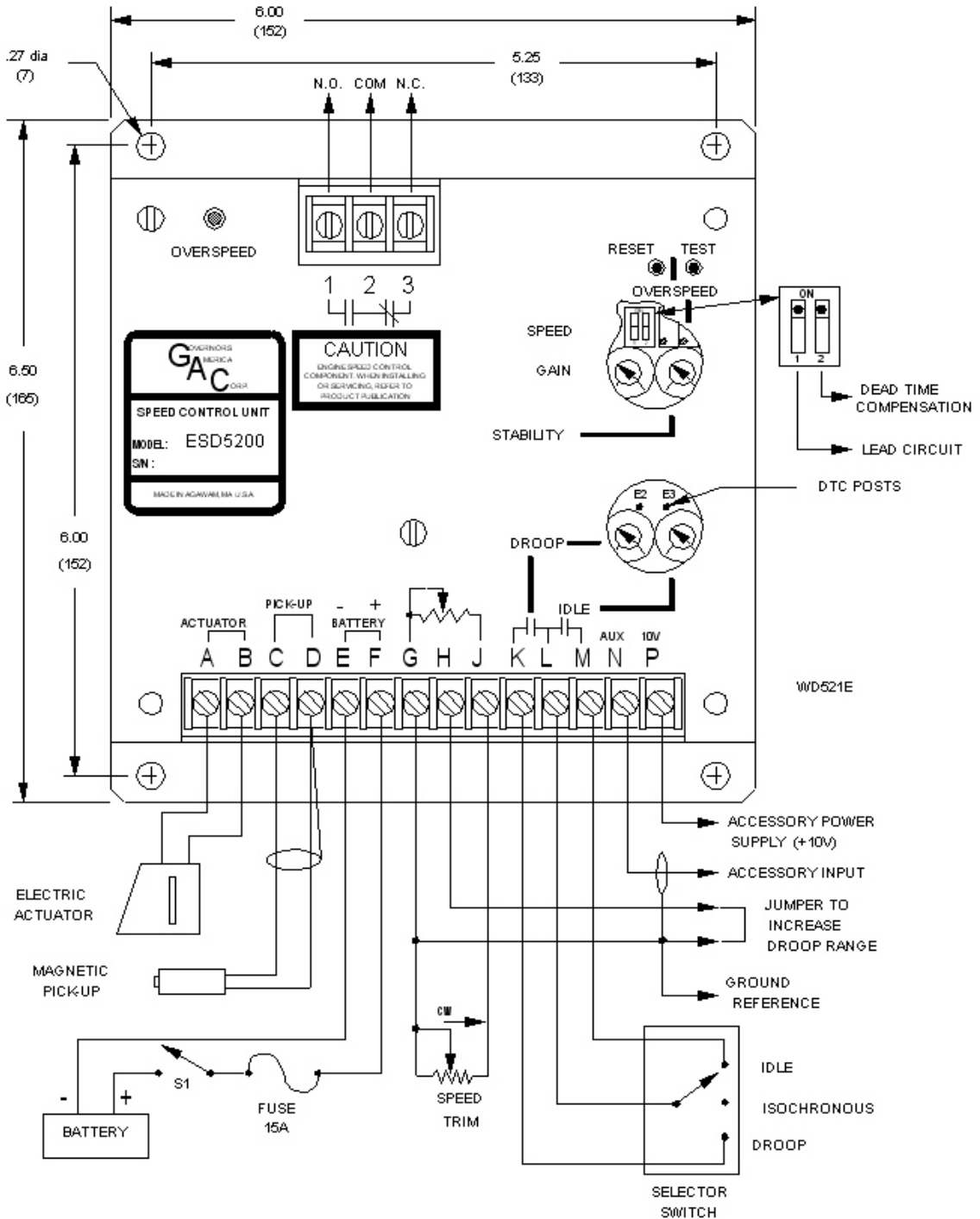

## 8 Specifications

### 8.1 Performance

Isochronous Operation/Steady State Stability .....	0.25% or better
Speed Range/Governor .....	1K-7.5K Hz continuous
Speed Drift with Temperature .....	±1% Maximum
Idle Adjust CW .....	Min. 1200 Hz. Below set speed
Idle Adjust CCW .....	Min. 4100 Hz. Below set speed
Droop Range .....	1 - 5% regulation*
Droop Adj. Max. (K-L Jumpered) .....	875 Hz., ± 75 Hz. per 1.0 A change
Droop Adj. Min. (K-L Jumpered) .....	15 Hz., ± 6 Hz. per 1.0 A change
Speed Trim Range .....	± 200 Hz.
Remote Variable Speed Range .....	500 - 7.5 Hz. or any part thereof
Terminal Sensitivity	
J .....	100 Hz., ± 15 Hz / Volt @ 5.0 K Impedance
L .....	735 Hz., ± 60 Hz / Volt @ 65 K Impedance
N .....	148 Hz., ± 10 Hz / Volt @ 1 Meg. Impedance
P .....	10 VDC Supply @ 20 ma Max.
Speed Switch Adjustment Range .....	1000 - 10000 Hz.

### 8.2 Environmental

Ambient Operating Temperature Range .....	-40 to +180°F (-40° to +85°C)
Relative Humidity .....	up to 95%
All Surface Finishes .....	Fungus Proof and Corrosion Resistant

### 8.3 Input Power

Supply .....	12 or 24V DC Battery Systems (Transient and Reverse Voltage Protected)**
Polarity .....	Negative Ground (Case Isolated)
Power Consumption .....	50 ma continuous plus actuator current
Actuator Current Range @ 77°F (25°C) .....	10 Amps continuous***
Speed Sensor Signal .....	0.5-120V AC RMS
Speed Switch Relay Contacts (N.O. and N. C.) .....	10 Amps

### 8.4 Reliability

Vibration .....	1G @ 20-100 Hz.
Testing .....	100% Functionally Tested

### 8.5 Physical

Dimensions .....	See Outline (DIAGRAM 2)
Weight .....	1.8 lbs. (820 grams)
Mounting .....	Any Position, Vertical Preferred

- \* Droop is based on a speed sensor frequency of 4000 Hz. and an actuator current change of 1 amp from no load to full load. Applications with higher speed sensor signals will experience less percentage of droop. Applications with more actuator current change will experience higher percentages of droop. See droop description for specific details on operation of droop ranges. When used with the ADC-100 actuator the droop percentage will be less due to the actuators low current consumption.
- \*\* Protected against reverse voltage by a series diode. A 15 amp fuse must be installed in the positive battery lead.
- \*\*\* Protected against short circuit to actuator (shuts off current to actuator), unit automatically turns back on when short is removed.